



6581 Kitimat Rd., Unit #6, Mississauga, Ontario, L5N 3T5

1-800-SENSOR2, FAX: 905-812-0771

www.systemsensor.ca

Selectable Output Chimes and Chime/Strobes

For use with the following models: CHSRA, CHSWA, CHRA, CHWA.

Specifications

General Specifications

Standard Operating Temperature:	32°F to 120°F (0°C to 49°C)
Humidity Range:	10 to 93% non-condensing
Strobe Flash Rate:	1 flash per second
Nominal Voltage:	Regulated 12DC/FWR or regulated 24DC/FWR ¹
Operating Voltage Range:	8 to 17.5 V (12V nominal) or 16 to 33 V (24 nominal)
Operating Voltage with MDL:	9 to 17.5 V (12V nominal) or 17 to 33 V (24 V nominal)

¹CHS products will operate at 12 V nominal only for 15 & 15/75 cd.

Mechanical Specifications

Input terminal wire gauge:	12 to 18 AWG
Chime/strobe dimensions (including lens):	5.6"Lx4.7"Wx2.5"D (142 mm Lx119 mm Wx64 mm D)
Chime dimensions:	5.6"Lx4.7"Wx1.3"D (142 mm Lx119 mm Wx33 mm D)

The products in this manual may be covered by one or more of the following patents: 5,593,569; 5,914,665; 5,850,178; 5,598,139; 6,049,446; 6,127,935; 6,133,843; 6,661,337; 6,833,783; 6,856,241; 6,822,400; 6,522,261.

General Description

Chimes and chime/strobes are private mode notification appliances used to alert trained personnel to investigate possible emergency situations and take appropriate action. SpectrAlert Advance chimes and chime/strobes are electrically backward compatible with the previous generation of notification appliances. While they are specifically designed for use on the wall, the products are listed to be used on the wall or ceiling. SpectrAlert products are designed to be used in either 12 or 24 volt DC or full wave rectified (FWR) systems. If required, the MDLA module may be used in order to provide synchronization.

NOTICE: This manual shall be left with the owner/user of this equipment.

Fire Alarm System Considerations

The National Fire Alarm Code, NFPA 72, requires that all horns, used for building evacuation installed after July 1, 1996, produce temporal coded signals. This is also a requirement by the National Building Code of Canada. Only the chime setting 5 that produces a minimum of 85 dBA temporal tone shall be used for fire alarm application. Signals other than those used for evacuation purposes do not have to produce the temporal coded signal.

Power Supply Considerations

Panels typically supply DC filtered voltage or FWR (full wave rectified) voltage. The system design engineer must calculate the number of units used on a loop based on the type of panel supply. Be certain the sum of all the device currents does not exceed the current capability of the panel. Calculations are based on using the device current found in the subsequent charts and must be compatible with the current specified for the panel or power supply used.

NOTE: SpectrAlert chimes and chime/strobes must be powered from a non-coded power supply.

Wire Sizes

The designer must be sure that the last device on the circuit has sufficient voltage to operate the device within its rated voltage. When calculating the voltage available to the last device, it is necessary to consider the voltage drop due to the resistance of the wire. The thicker the wire, the smaller the voltage drop. Generally, for purposes of determining the wire size necessary for the system, it is best to consider all of the devices as "lumped" on the end of the supply circuit to simulate worst case. For the most accurate voltage drop calculations use the System Sensor voltage drop calculator available on the web or CD-ROM.

Approximate wire resistance:

18 AWG solid:	8 ohms/1000 ft.
16 AWG solid:	5 ohms/1000 ft.
14 AWG solid:	3 ohms/1000 ft.
12 AWG solid:	2 ohms/1000 ft.

NOTE: If Class A wiring is installed, the wire length may be up to twice as long as on non-fault tolerant circuits.

Candela Selection for CHS series models

For strobe candela selection, adjust the slide switch located on the rear of the product while watching the viewing window under the reflector on the front of the unit. Use Table 1 to determine current draw at various candela and chime tone settings. Tables 2 and 3 can be used to determine strobe light output at various viewing angles.

NOTE: SpectrAlert products set at 15 and 15/75 candela automatically work on either 12V or 24V power supplies. The products are not listed for 12V operating voltages when set to any other candela settings.

Table 1. Current draw (mA)

	DC Input								
	8-17.5 Volts		16-33 Volts						
	15	15/75	15	15/75	30	75	95	110	115
1 Second Chime High	131	142	65	76	94	160	185	207	213
1 Second Chime Low	131	142	64	75	92	157	183	203	212
1/4 Second Chime High	129	142	66	75	95	159	184	205	212
1/4 Second Chime Low	129	142	64	74	91	155	181	204	211
Temporal Chime High	125	142	64	74	91	156	181	205	211
Temporal Chime Low	129	141	65	75	92	155	180	200	209
5 Second Whoop High	133	145	70	81	99	165	189	210	217
5 Second Whoop Low	130	143	66	77	95	160	186	206	214
One Time Chime	127	141	64	76	93	156	182	203	210
	FWR Input								
	8-17.5 Volts		16-33 Volts						
	15	15/75	15	15/75	30	75	95	110	115
1 Second Chime High	128	150	72	82	98	158	183	202	210
1 Second Chime Low	127	150	71	81	97	157	182	202	210
1/4 Second Chime High	129	149	72	82	99	160	183	203	211
1/4 Second Chime Low	128	149	71	81	97	154	179	196	205
Temporal Chime High	128	148	71	81	97	157	179	199	206
Temporal Chime Low	125	147	71	81	97	156	180	200	206
5 Second Whoop High	136	152	84	93	110	170	193	212	220
5 Second Whoop Low	132	150	77	86	102	161	184	203	214
One Time Chime	127	147	72	82	97	157	181	200	210

Table 2. Horizontal Plane Light Distribution for Wall and Ceiling Applications

Horizontal Angle	% Of Rated Light Output
0	100
45	75
90	25

Horizontal Plane Directional Sound Characteristics

Angle	dB output
0	93
30	90
80	87

Table 3. Vertical Plane Light Distribution for Wall Applications

Horizontal Angle	% Of Rated Light Output
0	100
45	34
90	12

Vertical Plane Directional Sound Characteristics

Angle	dB output
0	93
80	90
90	87

Installation

Installation should be done in accordance with the latest addition of CAN/ULC S524 and the Canadian Electrical Code CSA 22.1

Tone Selection

Chime tone setting selection is accomplished by using the rotary switch on the back of the product (see Table 4). The current draw for various tone settings for chimes is listed in Table 5. The sound measurements for various chime tone settings are shown in Table 6 for chime and chime/strobe products.

Table 4. Chime Patterns

Setting	Repetition Rate	dB Out
1	1 Second Chime	High
2	1 Second Chime	Low
3	1/4 Second Chime	High
4	1/4 Second Chime	Low
5	Temporal Chime	High
6	Temporal Chime	Low
7	5 Second Whoop	High
8	5 Second Whoop	Low
9	One Test Chime	High

Table 5. Chime Current Draw (mA)

Sound Pattern	dB	8–17.5 Volts		16–33 Volts	
		DC	FWR	DC	FWR
1 Second Chime	High	34	50	58	51
1 Second Chime	Low	30	51	51	54
1/4 Second Chime	High	34	51	50	50
1/4 Second Chime	Low	31	51	50	52
Temporal Chime	High	30	50	48	54
Temporal Chime	Low	30	47	50	51
5 Second Whoop	High	32	52	34	54
5 Second Whoop	Low	30	40	34	52
One Test Chime	High	48	49	50	50

Table 6. Chime & Chime/Strobe Output (dBA)

Switch Position	Sound Pattern	dB	8–17.5 Volts		16–33 Volts	
			DC	FWR	DC	FWR
1	1 Second Chime	High	82	85	85	85
2	1 Second Chime	Low	76	79	77	77
3	1/4 Second Chime	High	82	84	84	85
4	1/4 Second Chime	Low	76	78	78	78
5	Temporal Chime	High	85	90	90	93
6	Temporal Chime	Low	79	80	80	80
7	5 Second Whoop	High	87	93	92	97
8	5 Second Whoop	Low	80	83	83	83
9	One Test Chime	High	82	84	84	86

Wiring

Figure 1. Non-Synchronized devices; any combination of models powered by a 2-wire circuit

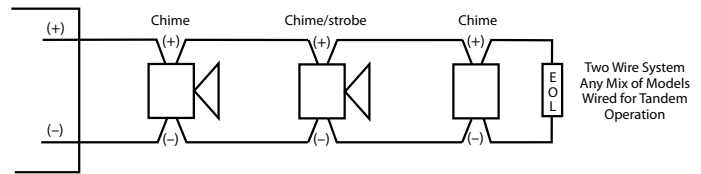
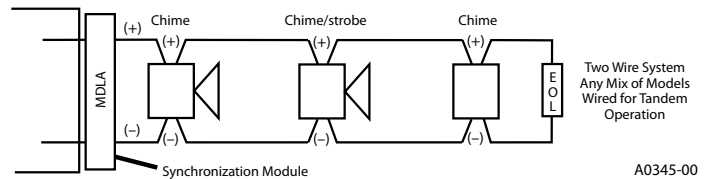

Figure 2. Synchronized devices; any combination of models powered by a 2-wire circuit



NOTE: For further information on synchronization see MDLA, panel, or power supply installation manual.

Terminal Definitions

Figure 3.

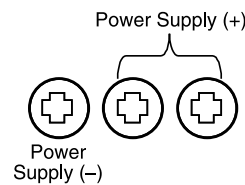

A0350-00

Mounting

Figure 4.

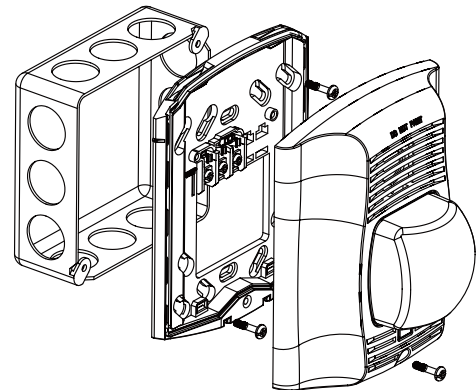

A0353-00

1. Attach mounting plate to junction box. The mounting plate is compatible with 4" square, single gang, double gang, and 4" octagon junction boxes. If using a back box skirt, attach the mounting plate to the skirt and then attach the entire assembly to the junction box.
2. Connect field wiring according to terminal definitions.
3. If the product is not to be installed at this point, use the dust cover to prevent contamination of the wiring terminals of the mounting plate.
4. To attach product to mounting plate, hook tabs on the product housing into the grooves on mounting plate. Then, swing product into position to engage the pins on the product with the terminals on the mounting plate. Make sure that the tabs on the back of the product housing fully engage with the mounting plate.
5. Secure product by tightening the single mounting screw in the front of the product housing.

Please refer to insert for the Limitations of Fire Alarm Systems



The Limitations of Horn/Strobes

The horn and/or strobe will not work without power. The horn/strobe gets its power from the fire/security panel monitoring the alarm system. If power is cut off for any reason, the horn/strobe will not provide the desired audio or visual warning.

The horn may not be heard. The loudness of the horn meets (or exceeds) current Underwriters Laboratories' standards. However, the horn may not alert a sound sleeper or one who has recently used drugs or has been drinking alcoholic beverages. The horn may not be heard if it is placed on a different floor from the person in hazard or if placed too far away to be heard over the ambient noise such as traffic, air conditioners, machinery or music appliances that may prevent alert persons from hearing the alarm. The horn may not be heard by persons who are hearing impaired.

NOTE: Strobes must be powered continuously for horn operation.

The signal strobe may not be seen. The electronic visual warning signal uses an extremely reliable xenon flash tube. It flashes at least once every second. The strobe must not be installed in direct sunlight or areas of high light intensity (over 60 foot candles) where the visual flash might be disregarded or not seen. The strobe may not be seen by the visually impaired.

The signal strobe may cause seizures. Individuals who have positive photoic response to visual stimuli with seizures, such as persons with epilepsy, should avoid prolonged exposure to environments in which strobe signals, including this strobe, are activated.

The signal strobe cannot operate from coded power supplies. Coded power supplies produce interrupted power. The strobe must have an uninterrupted source of power in order to operate correctly. System Sensor recommends that the horn and signal strobe always be used in combination so that the risks from any of the above limitations are minimized.

Three-Year Limited Warranty

System Sensor warrants its enclosed device to be free from defects in materials and workmanship under normal use and service for a period of three years from date of manufacture. System Sensor makes no other express warranty for this smoke detector. No agent, representative, dealer, or employee of the Company has the authority to increase or alter the obligations or limitations of this Warranty. The Company's obligation of this Warranty shall be limited to the repair or replacement of any part of the smoke detector which is found to be defective in materials or workmanship under normal use and service during the three year period commencing with the date of manufacture. After phoning System Sensor's toll free number 1-800-SENSOR2 (736-7672) for a Return Authorization number, send defective units postage prepaid to: System Sensor, Repair Department, RA # _____, 6581 Kitimat Rd., Unit

#6, Mississauga, Ontario, L5N 3T5. Please include a note describing the malfunction and suspected cause of failure. The Company shall not be obligated to repair or replace units which are found to be defective because of damage, unreasonable use, modifications, or alterations occurring after the date of manufacture. In no case shall the Company be liable for any consequential or incidental damages for breach of this or any other Warranty, expressed or implied whatsoever, even if the loss or damage is caused by the Company's negligence or fault. Some states do not allow the exclusion or limitation of incidental or consequential damages, so the above limitation or exclusion may not apply to you. This Warranty gives you specific legal rights, and you may also have other rights under common law.

FCC Statement

SpectraAlert Strobes and Horn/Strobes have been tested and found to comply with the limits for a Class B digital device, pursuant to part 15 of the FCC Rules. These limits are designed to provide reasonable protection against harmful interference when the equipment is operated in a commercial environment. This equipment generates, uses,

and can radiate radio frequency energy and, if not installed and used in accordance with the instruction manual, may cause harmful interference to radio communications. Operation of this equipment in a residential area is likely to cause harmful interference in which case the user will be required to correct the interference at his own expense.