

Selectable Output Chimes and Chime/Strobes



6-6581 Kitimat Road Mississauga, Ontario, L5N 3T5

PH: 905.812.0767 / FAX: 905.812.0771 / TOLL: 800.SENSOR2 / WEB: www.systemsensor.ca

Models Available

Red and White

Chime

Chime/Strobe



Chime/Strobe (CHSRA)



Chime (CHWA)

French and Bilingual Models Available

Product Overview

Plug-in design

Shorting spring on mounting plate for pre-installation continuity check

Captive mounting screw

Torx screw for tamper resistance

Field-selectable candela settings: 15, 15/75, 30, 75, 95, 110, 115

Automatic selection of 12- or 24-volt operation at 15 and 15/75 candela

Minimal intrusion into the back box

Rotary switch for tone selection

Two volume settings

Electrically compatible with existing SpectrAlert products

SpectrAlert® Advance selectable-output chimes and chime/strobes are notification appliances used to alert trained personnel to investigate possible emergency situations and to take appropriate action. Security guard and nurse workstations are ideal locations for chime products.

SpectrAlert Advance chimes and chime/strobes are rich with features guaranteed to cut installation times and maximize profits. The SpectrAlert Advance series of notification appliances is designed to simplify your installations, with features such as: plug in designs, instant feedback messages to ensure correct installation of individual devices, and seven field-selectable candela settings for chime/strobes.

More specifically, when installing Advance products, first attach a universal mounting plate to a four-inch square, four-inch octagon, single-gang, or double-gang junction box.

Then, connect the notification appliance circuit wiring to the SEMS terminals on the mounting plate.

Finally, attach the chime or chime/strobe to the mounting plate by inserting the product's tabs in the mounting plate's grooves. The device will rotate into position, locking the product's pins into the mounting plate's terminals. The device will temporarily hold in place with a catch until it is secured with a captive mounting screw.

SpectrAlert Advance products allow you to choose:

- 12 or 24 volts
- At 24 volts, 15, 15/75, 30, 75, 95, 110, or 115 candela by way of rear-mounted slide switch and front view window
- Chime tones and volume by way of rotary switch



Engineering Specifications

General

SpectrAlert Advance chimes and chime/strobes shall mount to a standard $4 \times 4 \times 1\frac{1}{2}$ -inch back box, 4-inch octagon back box, single-gang $2 \times 4 \times 1\frac{7}{8}$ -inch back box, or double-gang back box. A universal mounting plate shall be used for mounting products. The notification appliance circuit wiring shall terminate at the universal mounting plate. Also, SpectrAlert Advance products, when used with the Sync-Circuit Module accessory, shall be powered from a non-coded notification appliance circuit output and shall operate on a nominal 12 or 24 volts. When used with the Sync-Circuit Module, 12-volt rated notification appliance circuit outputs shall operate between nine and 17.5 volts; 24-volt rated notification appliance circuit outputs shall operate between 17 and 33 volts. Indoor SpectrAlert Advance products shall operate between 40 and 66 degrees Celcius from a regulated DC, or full-wave rectified, unfiltered power supply. Chime/strobes shall have field-selectable candela settings of 15, 15/75, 30, 75, 95, 110 and 115.

Chime/Strobe Combination

The chime/strobe shall be a System Sensor SpectrAlert Advance Model _____ listed to CAN/ULC S525 and S526. The chime/strobe

shall comply with the Americans with Disabilities Act requirements for visible signaling appliances, flashing at 1Hz over the strobe's entire operating voltage range. The strobe light shall consist of a xenon flash tube and associated lens/reflector system. The chime shall have two audibility options and an option to switch between a temporal three-pattern and a non-temporal (continuous) pattern. These options are set by a multiple position switch.

Synchronization Module

The module shall be a System Sensor Sync-Circuit _____ listed to ULC and shall be approved for fire protective service. The module shall synchronize SpectrAlert strobes at 1Hz and chimes at temporal three. Also, while operating the strobes, the module shall silence the chimes on chime/strobe models over a single pair of wires. The module shall mount to a $4\frac{11}{16} \times 4\frac{11}{16} \times 2\frac{1}{8}$ -inch back box. The module shall also control two Style Y (class B) circuits or one Style Z (class A) circuit. The module shall synchronize multiple zones. Daisy chaining two or more synchronization modules together will synchronize all the zones they control. The module shall not operate on a coded power supply.

Specifications

Standard Operating Temperature

0°C to 49°C (32°F to 120°F)

Humidity Range

10 to 93% non-condensing
(indoor products)

Strobe Flash Rate

1 flash per second

Nominal Voltage

Regulated 12DC/FWR or regulated
24DC/FWR¹

Operating Voltage Range²

8 to 17.5 V (12V nominal) or 16 to 33 V
(24 nominal)

Input terminal wire gauge

12 to 18 AWG

Chime/strobe dimensions

(including lens)

5.6~L × 4.7~W × 2.5~D
(142 mm L × 119 mm W × 64 mm D)

Chime dimensions

5.6~L × 4.7~W × 1.3~D
(142 mm L × 119 mm W × 33 mm D)

Notes:

1. Full Wave Rectified (FWR) voltage is a non-regulated, time varying power source that is used on some power supply and panel outputs.
2. CHS products will operate at 12 V nominal only for 15 and 15/75 cd.

Max. Current Draw (mA RMS)

	DC Input								
	8-17.5 Volts			16-33 Volts					
	15	15/75	15	15/75	30	75	95	110	115
1 Second Chime High	131	142	65	76	94	160	185	207	213
1 Second Chime Low	131	142	64	75	92	157	183	203	212
1/4 Second Chime High	129	142	66	75	95	159	184	205	212
1/4 Second Chime Low	129	142	64	74	91	155	181	204	211
Temporal Chime High	125	142	64	74	91	156	181	205	211
Temporal Chime Low	129	141	65	75	92	155	180	200	209
5 Second Whoop High	133	145	70	81	99	165	189	210	217
5 Second Whoop Low	130	143	66	77	95	160	186	206	214
One Time Chime	127	141	64	76	93	156	182	203	210
	FWR Input								
	8-17.5 Volts			16-33 Volts					
	15	15/75	15	15/75	30	75	95	110	115
1 Second Chime High	128	150	72	82	98	158	183	202	210
1 Second Chime Low	127	150	71	81	97	157	182	202	210
1/4 Second Chime High	129	149	72	82	99	160	183	203	211
1/4 Second Chime Low	128	149	71	81	97	154	179	196	205
Temporal Chime High	128	148	71	81	97	157	179	199	206
Temporal Chime Low	125	147	71	81	97	156	180	200	206
5 Second Whoop High	136	152	84	93	110	170	193	212	220
5 Second Whoop Low	132	150	77	86	102	161	184	203	214
One Time Chime	127	147	72	82	97	157	181	200	210

Tone Selection

Chime tone selection is accomplished by using the rotary switch on the back of the product. The current draw and sound measurements for various chime tone settings are listed below.

Chime Patterns

Setting	Repetition Rate	dB Out
1	1 Second Chime	High
2	1 Second Chime	Low
3	1/4 Second Chime	High
4	1/4 Second Chime	Low
5	Temporal Chime	High
6	Temporal Chime	Low
7	5 Second Whoop	High
8	5 Second Whoop	Low
9	One Test Chime	High

Chime & Chime/Strobe Output (dB - Anechoic Room)

Switch Position	Sound Pattern	dB	8-17.5 Volts		16-33 Volts	
			DC	FWR	DC	FWR
1	1 Second Chime	High	82	85	85	85
2	1 Second Chime	Low	76	79	77	77
3	1/4 Second Chime	High	82	84	84	85
4	1/4 Second Chime	Low	76	78	78	78
5	Temporal Chime	High	85	90	90	93
6	Temporal Chime	Low	79	80	80	80
7	5 Second Whoop	High	87	93	92	97
8	5 Second Whoop	Low	80	83	83	83
9	One Test Chime	High	82	84	84	86

Max. Chime Current Draw (mA RMS)

Sound Pattern	dB	8-17.5 Volts		16-33 Volts	
		DC	FWR	DC	FWR
1 Second Chime	High	34	50	58	51
1 Second Chime	Low	30	51	51	54
1/4 Second Chime	High	34	51	50	50
1/4 Second Chime	Low	31	51	50	52
Temporal Chime	High	30	50	48	54
Temporal Chime	Low	30	47	50	51
5 Second Whoop	High	32	52	34	54
5 Second Whoop	Low	30	40	34	52
One Test Chime	High	48	49	50	50

SpectrAlert Advance Dimensions

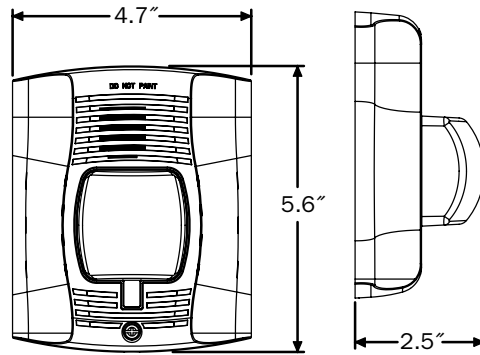

SpectrAlert Advance Ordering Information

Model	Description
CHRA	Chime, Red
CHWA	Chime, White
CHSRA	Chime/strobe, Red
CHSWA	Chime/strobe, White
BBS-2	Back Box Skirt, Wall, Red
BBSW-2	Back Box Skirt, Wall, White

Add suffix **“-F”** for French or **“-B”** for Bilingual

System Sensor Sales and Service

System Sensor Canada
6581 Kitimat Rd. Unit # 6
Mississauga, ON L5N 3T5
Ph: 800-SENSOR2
Fx: 905-812-0771

www.systemsensor.ca

System Sensor Headquarters USA
Ph: 630-377-6674
Fx: 630-377-6495

System Sensor in Europe
Ph: 44.1403.276500
Fx: 44.1403.276501

System Sensor in China
Ph: 86.29.524.6253
Fx: 86.29.524.6259

System Sensor in Singapore
Ph: 65.273.2230
Fx: 65.273.2610

System Sensor– Far East
Ph: 852.21919003
Fx: 852.27366580

System Sensor– Latin America
Ph: 562.214.9359
Fx: 562.214.2987