

Single-Ended Reflected Beam Smoke Detector

Single-Ended Reflected Beam Smoke Detector

Contents	
Section 1	Principles of Operation 2 Accessories 2
Section 2	Beam Smoke Detectors vs. Spot-Type Smoke Detectors 2 Coverage 2 Ceiling Height 2 High Air Velocity 3 Stratification 3 Pre-stratification/Heat Release Rate 4 Special Applications 4
Section 3	Design Considerations 5 Sensitivity 5 Location and Spacing 5 Mounting Considerations for Reflected Beam Smoke Detectors 5 Additional Mounting Considerations for Reflected Beam Smoke Detectors 6
Appendix A	Glossary of Terms 7
Appendix B	NFPA 92B3.3.4.3 7

Foreword

Beam smoke detectors can be important components of a well designed automatic fire alarm system. Because of their capabilities, beam detectors can overcome some of the limitations of spot-type smoke detectors. This guide was developed to help the fire alarm designer gain an understanding of the beam smoke detector’s capabilities and when they may be the preferred technology for a particular application.

The guide provides information on the proper utilization of beam smoke detectors in life-safety and property protection applications. In addition, it summarizes the operating principles of single-ended reflected beam smoke detectors, their design requirements, and their practical applications as a component of an automatic fire alarm system.

Although beam smoke detectors are not suited for all applications, they may be the detector of choice in many applications where spot-type detectors are not practical.

Because equipment from different manufacturers has varying specifications and listings, the information in this guide is general in nature and should not be substituted for the manufacturer’s recommendations or code requirements.

Section 1
Principles of Operation

The detector works on the principle of light obscuration. The photosensitive element sees light produced by the transceiver unit in a normal condition. The transceiver unit is calibrated to a preset sensitivity level based on a percentage of total obscuration. This sensitivity level is determined by the manufacturer based on the length of

Reflected beam smoke detectors consist of a transceiver (a transmitter/receiver) unit that projects, monitors, and receives a beam reflected across the protected area.

beam is not a typical smoke signature, the detector will see this as a trouble condition, not an alarm.

In addition, very small, slow changes in the quality of the light source are not typical of a smoke signature. These changes may occur because of environmental conditions such as dust and dirt accumulation on the transceiver unit's optical assemblies or on the reflective surface.

When the detector is first turned on and put through its setup program, it assumes the light signal level at that time as a reference point for a normal condition. As the quality of the light signal degrades over time, the Automatic Gain Control (AGC) compensates for the change. The rate of compensation, however, is limited to ensure that the detector will still be sensitive to slow building or smoldering fires. When the AGC can no longer compensate for the loss of the signal, perhaps due to an excessive accumulation of dust or dirt, the detector will signal a trouble condition.

Accessories

Accessories to the beam smoke detector may include remote annunciators, as well as remote test stations which allow for the periodic electronic and/or sensitivity testing of the detector. Intelligent fire alarm systems can give the beam smoke detector a discrete address to provide better annunciation of the fire location.

Additional accessories that can be used with reflected beam smoke detectors include surface-mount kits, multi-mount kits, and long-range kits. Surface-mount kits allow reflected beam detectors to be mounted when surface wiring is used. Multi-mount kits allow reflected beam detectors and reflectors to be mounted to either the wall or ceiling. The surface mount kit must be used when installing the multi-mount kit to the detector. Long-range kits allow the reflected beam detector to be installed at longer distances from the reflector, typically 230 to 328 feet or 70 to 100 meters.

Heaters allow the optical surface of the beam detector and reflector to maintain a slightly higher temperature than the surrounding air. This helps to minimize condensation in environments that experience temperature fluctuations.

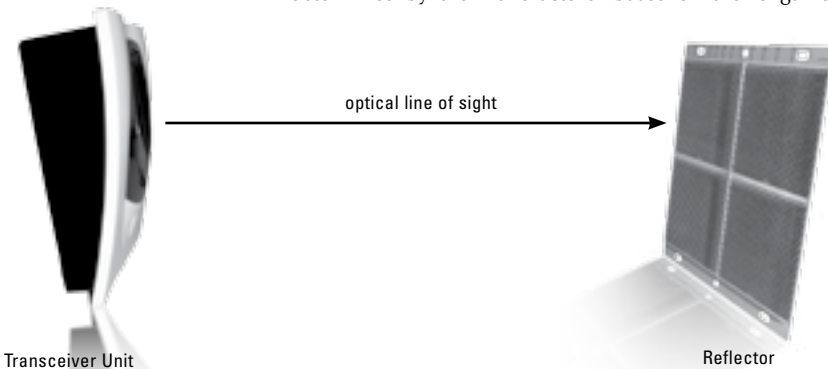

Transceiver Unit
Figure 1

the beam, the distance between the transceiver unit and reflector. For UL listed detectors the sensitivity setting must comply with UL Standard 268, Smoke Detectors for Fire Protective Signaling Systems.

Beam smoke detectors operate on the principle of obscuration. As a smoke field develops, the detector senses the cumulative obscuration – the percentage of light blockage created by a combination of smoke density and the linear distance of the smoke field across the projected light beam. The threshold is typically set by the manufacturer to match the conditions of the installation.

Choosing the appropriate sensitivity minimizes the possibility of nuisance alarms that would result from a blockage of the beam by a solid object placed inadvertently in its path. Since the sudden and total obscuration of the light

Section 2
Beam Smoke Detectors vs. Spot-Type Smoke Detectors

and applying beam smoke detectors to fire alarm systems.

Beam detectors are governed by UL and NFPA 72, 2007, Section 5.7.3.4. It is important that designers understand and give full consideration to these requirements when selecting

and other factors, such as room geometry, may impose practical reductions of this maximum coverage.

Spot-type smoke detectors are considered to have a maximum coverage of 900 square feet. The maximum length between detectors is 41 feet when the width of the area being protected does not exceed 10 feet, as in a hallway.

Coverage

Beam smoke detectors can cover an area which would require a dozen or more spot-type detectors. Fewer devices mean lower installation and maintenance costs.

Beam smoke detectors generally have a maximum range of 330 feet and a maximum spacing between detectors of 60 feet. This gives the beam smoke detector theoretical coverage of 19,800 square feet. Manufacturer's recommen-

Ceiling Height

Although spot-type smoke detector's response time generally increases as its distance from the fire/floor increases, this is not necessarily the case with beam smoke detectors, which are ideally suited for high ceiling applications. Some manufacturers, however, may require additional detectors as ceiling height increases. This is because of the anticipated behavior of a plume of smoke.

Fires usually start at or near floor level. When that occurs, the smoke rises up to, or near the ceiling. Typically the

column of smoke begins to spread out as it travels from its point of origin, forming a smoke field in the shape of an inverted cone.

The density of the smoke field can be affected by the rate of growth of the fire. Fast fires tend to produce more uniform density than slow burning fires, where there may be dilution at the upper elevations of the smoke field.

In some applications, especially where high ceilings are present, beam smoke detectors may be more responsive to slow or smoldering fires than spot-type detectors because they are looking across the entire smoke field intersecting the beam. Spot-type detectors only sample smoke at their particular “spot.” The smoke which enters the chamber may be diluted below the level of smoke needed to activate an alarm.

High Air Velocity

High air movement areas present a special problem for spot-type detectors, because the propagation of smoke developing under normal conditions may not occur. Since high air velocity may blow smoke out of the sensing chamber, careful consideration should be given to the spot-type detector’s performance where air velocities exceed 1,500 feet per minute or when air changes in the protected area exceed 7.5 changes per hour. A beam smoke detector’s sensing range can be as long as a football field (maximum beam range is typically 330 feet), compared to the one- or two-inch dimension of a spot-type sensing chamber. It is, therefore, less likely that smoke will be blown out of the beam smoke detector’s sensing range. Because high air movement does not have as great an effect on beam detectors, they are not typically required to be listed for this type environment.

Theoretical Maximum Area Coverage

Beam Detector
19,800 sq. ft. (330 ft. x 60 ft.)

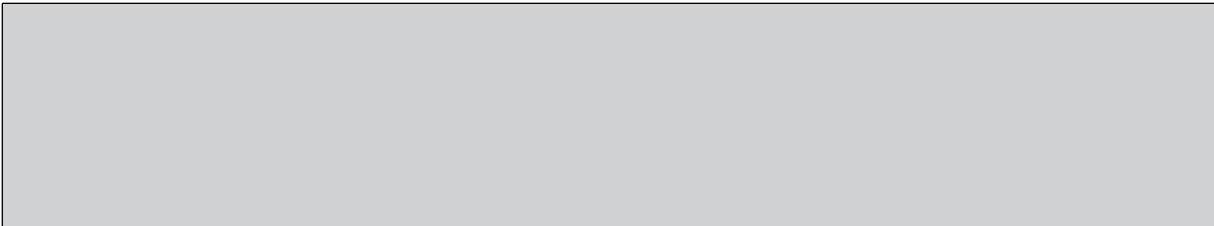

Spot-Type Detector
900 sq. ft. (30 ft. x 30 ft.)



Figures 2 and 3
Beam vs. Spot-Type Detectors

A limitation of beam smoke detectors is that as line-of-sight devices, they are subject to interference from any object or person, which enters the beam’s path. As a result, their use is impractical in most occupied areas with normal ceiling heights.

Beam smoke detectors, however, are often the detectors of choice in facilities with high ceilings, such as atria, lobbies, gymnasiums, sports arenas, museums, plane hangars, and church sanctuaries, as well as factories and warehouses. Many of these applications present special problems for the installation of spot-type detectors, and even greater problems for their proper maintenance. The use of beam smoke detectors in many of these areas may reduce problems since fewer devices may be required, and the devices can be mounted on walls, which are more accessible than ceilings. Application for high ceiling areas are described in the NFPA 92B, Guide for Smoke Management in Malls, Atria and Large Areas.

Stratification

Stratification occurs when smoke is heated by smoldering or burning materials and becomes less dense than surrounding cooler air. The smoke rises until there is no longer a difference in temperature between the smoke and the surrounding air. (See NFPA 72-2007, A.5.7.1.10.) Stratification, therefore, may occur in areas where air temperature may be elevated at the ceiling level, especially where there is a lack of ventilation.

On smooth ceilings, beam smoke detectors generally should be mounted within their listed spacing. In a few cases, the location and sensitivity of the detectors shall be the result of an engineering evaluation that includes the following:

- structural features
- size and shape of the room and bays
- occupancy and uses of the area
- ceiling height
- ceiling shape
- surface and obstructions
- ventilation

Inverted Cone Smoke Field

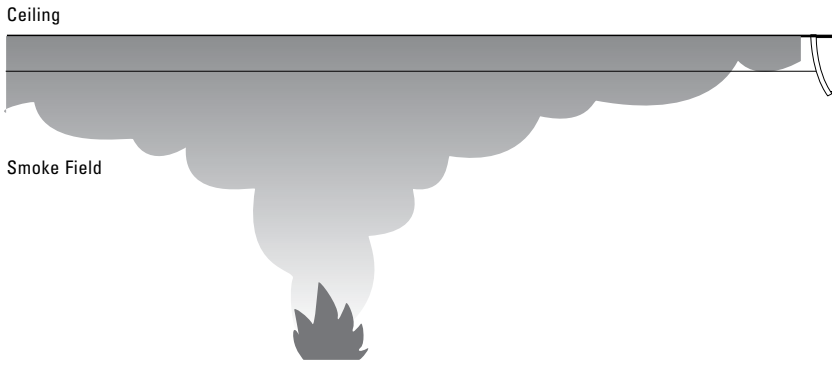
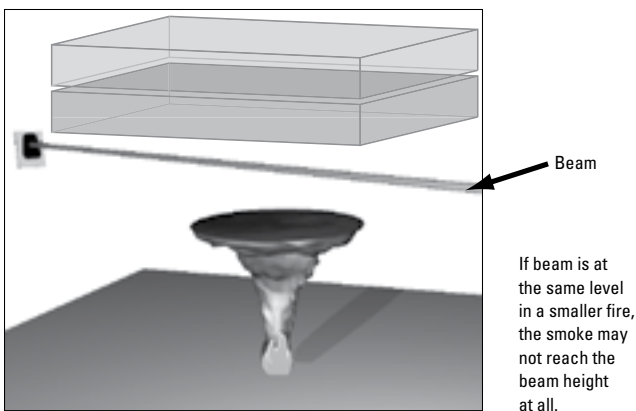
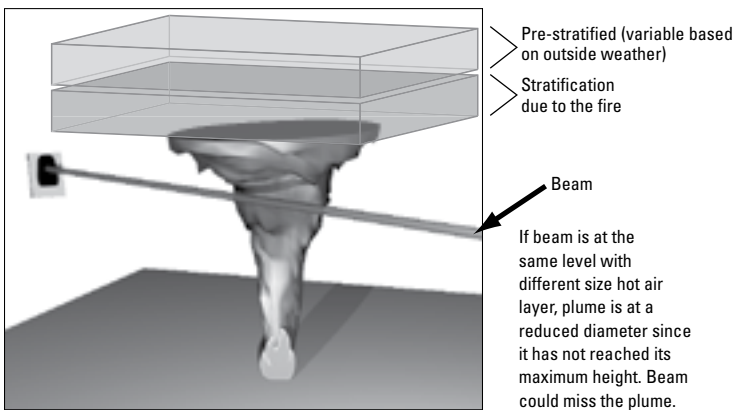
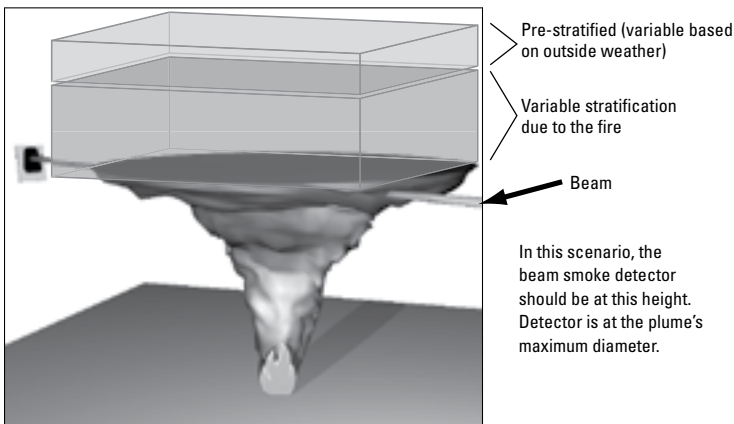

Figure 4. Typical smoke field in the shape of an inverted cone



Figures 5, 6, 7. Pre-stratification and detector placement

- ambient environment
- burning characteristics of the combustible materials present, and
- the configuration of the contents in the area to be protected

The results of an engineering evaluation may require an installation farther from the ceiling and at different levels to defeat the effects of stratification or other obstructions.

Pre-stratification/Heat Release Rate

Pre-stratification needs to be considered, since it is a predominant factor in atria with glass ceilings. During sunny periods, heat can build up inside the top of the atrium, creating a stratified layer at the ceiling level before the fire begins. The depth of the hot air layer will change depending upon the outside temperature and the intensity of the sun shining on the roof. The heat from the fire can further add to this hot air layer and increase its depth. (See Figures 5-7.)

The heat release rate of a fire will govern the height to which smoke will rise in an atrium. Heat release rates vary according to the material that is being burned and the mass of the material, among other variables

When determining the height at which beam detectors will be placed, many possible fire scenarios need to be considered. Fire scenarios should be based not only on items normally in the area, but also on transient hazards such as items used during remodeling or during the period when tenants are moving in and out.

Special Applications

One of the major limitations of spot-type smoke detectors is their inability to survive in hostile environments, such as temperature extremes, dirt, humidity, and corrosive gases. Although beam smoke detectors may be subject to some of these debilitating elements, they are a good alternative in many instances because their operating temperature range may be much wider than spot-type smoke detectors. Possible applications for beam detectors include freezers, cold storage warehouses, shipping warehouses, enclosed parking facilities, concert halls, and barns.

Beam detectors, however, should not be installed in environments where there is no temperature control and condensation or icing is likely. If elevated humidity levels and rapidly changing temperatures can be expected in those areas, then condensation likely will form, and the application is not acceptable for the beam detector. Also, the beam detector should not be installed in locations where the transceiver unit, the reflector, or the optical pathway between them may be exposed to outdoor conditions such as rain, snow, sleet, or fog. These conditions will impair the proper operation of the detector.

Section 3
Design
Considerations

Many factors affect the performance of smoke detectors. The type and amount of combustibles, the rate of fire growth, the proximity of the detector to the fire, and ventilation factors are all important considerations. UL Listed beam smoke detectors are tested using the UL 268 Standard, Smoke Detectors for Fire Protective Signaling Systems, and should be installed and maintained in accordance with NFPA 72, The National Fire Alarm Code and the manufacturer’s instruction.

Sensitivity

Each manufacturer requires that the detector’s sensitivity be set with reference to the length of the beam used on a given application. The detector should be installed within the minimum and maximum beam length allowed by the manufacturer’s instructions, which are limited by the UL listing.

Location and Spacing

Location and spacing parameters are recommended by manufacturers. For example, on smooth ceilings, a space of not more than 60 feet (18.3 meters) between projected beams, and one-half of the maximum spacing between a projected beam and a sidewall (wall parallel to the beam travel) may be used as a guide. Although the above example allows a maximum of 60-foot spacing between detectors, some manufacturer’s recommendations may limit this criterion.

Mounting Consideration for Reflected Beam Smoke Detectors

Beam detectors require a stable mounting surface for proper operation. A surface that moves, shifts, vibrates, or warps over time will cause false alarms or trouble conditions.

Mount the detector on a stable mounting surface, such as brick, concrete, a sturdy load-bearing wall, support column, structural beam, or other surface that is not expected to experience vibration or movement over time. Do not mount the beam detector on corrugated metal walls, sheet

metal walls, external building sheathing, external siding, suspended ceilings, steel web trusses, rafters, nonstructural beam, joists, or other such surfaces.

In cases where only one stable mounting surface as defined above can be used, the transceiver unit should be mounted to the stable surface and the reflector should be mounted to the less stable surface. The reflector has a much greater tolerance for the unstable mounting locations.

Because beam smoke detectors are line-of-sight devices, which go into trouble on sudden and total loss of signal, care must be taken that all opaque obstacles are kept clear of the beam path at all times. (See NFPA 72-2007).

“In some cases, the light beam projector (same as transmitter/receiver) is mounted on one end wall, with the light beam receiver (same as reflector) mounted on the opposite wall. However, it is also permitted to suspend the projector and receiver from the ceiling at a distance from the end walls not exceeding one-quarter the selected spacing.” — NFPA 72-2007, A-5.7.3.4

Consideration must be given, as well, to the need for a rapid response due to life safety factors or the high value of the assets being protected. Spacing should be reduced where these factors apply, or where the anticipated fire will produce limited smoke, especially in its early stages. Ceiling mounted detectors in a very high atrium of a hotel, for instance, may need to be supplemented by additional detectors at lower elevations.

In applications where reduced spacing is required, care should be taken to keep two parallel beams at a minimum distance so that the receiver from one detector cannot see the light source from another detector. Where two or more detectors are installed with their respective beams at angles, care should be taken that the receiver of each detector can sense only the light from its own transmitter. It is important to follow the manufacturer’s testing procedures in the manual.

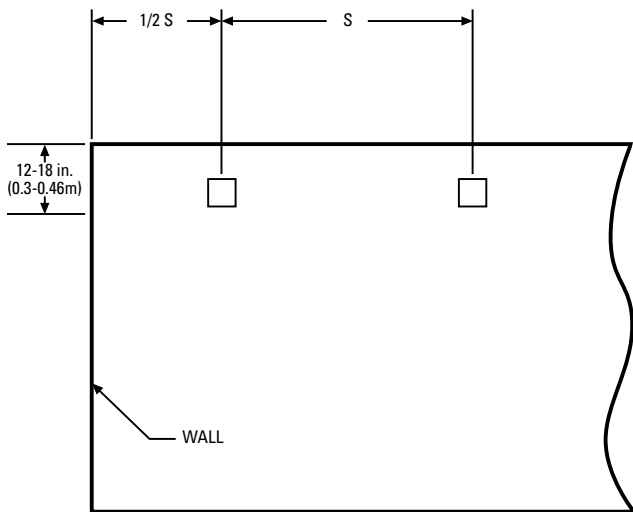

Side View

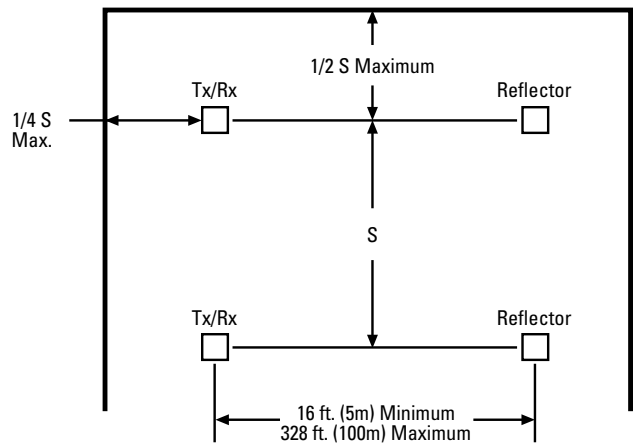

Top View

Figures 8 and 9. Spacing for Smooth Ceiling

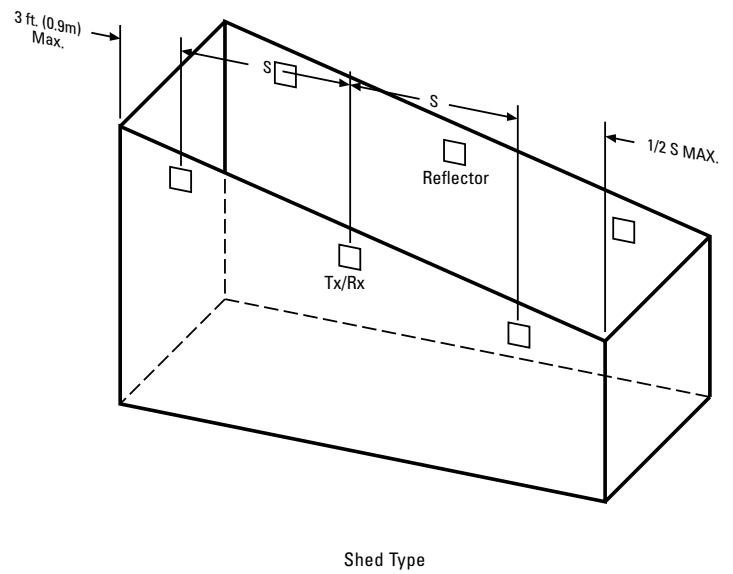
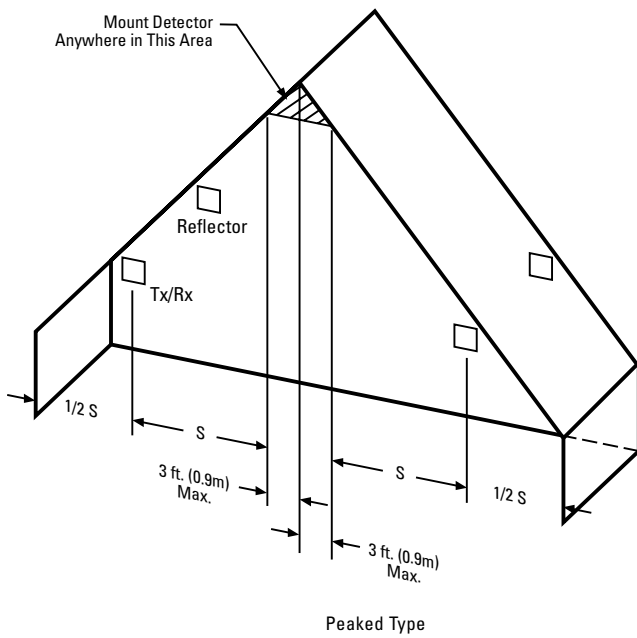

Figures 10 and 11. Mounting on Sloped Ceilings

Additional Mounting Considerations for Reflected Beam Smoke Detectors

There must be a permanent clear line of vision between the detector and the reflector. Reflective objects must not be near the line of vision between the detector and reflector. Reflective objects too near to the line of sight can reflect the light beam from the transmitter to the receiver. If this occurs, the detector will not be able to distinguish these reflections from those of the reflector, and the protected space will be compromised. Reflective objects should be a minimum of 15 inches (38.1cm) from the line of sight between the detector and reflector.

Light sources of extreme intensity such as sunlight and halogen lamps, if directed at the receiver, can cause a dramatic signal change resulting in fault and alarm signals. To prevent this problem, direct sunlight into the transceiver unit should be avoided. There should be a minimum of 10 degrees between the pathway of the light source (sunlight) and detector, and the line of sight between detector and reflector.

Operation of the detector through panes of glass should be avoided. Since single ended beam detectors operate on a reflection principle, a pane of glass perpendicular to the

line of sight between the detector and the reflector can reflect the light beam from the transmitter to the receiver. If this occurs, the detector will not be able to distinguish these reflections from those of the reflector and the protected space will be compromised.

Panels of glass will also absorb some of the light as it passes through it. This absorption of light will reduce the acceptable installed distance between the detector and the reflector.

In cases where operation through panes of glass cannot be avoided, some specific installation practices can help to minimize the effects of the glass. These practices include avoiding penetration of multiple panes of glass, positioning the glass so that it is not perpendicular to the line of sight between the detector and the reflector (a minimum of 10 degrees off perpendicular should be considered), and making certain that the glass is smooth, clear and mounted securely. The complete reflector blockage test can be used to determine if the installation is acceptable.

Where high ceilings (in excess of 30 feet or 9.1 meters) are present, additional beams may be required to detect smoke at lower levels.

Appendix A Glossary of Terms

Annunciator

A device which gives a visible or audible indication of the condition or status, such as normal, trouble, or alarm, of a smoke detector or system.

Automatic Gain Control (AGC)

The ability of a beam smoke detector to compensate for light signal degradation due to dust or dirt. Rate of compensation is limited to ensure that the detector is still sensitive to slow, smoldering fires.

Beam Smoke Detector (Reflected Beam Smoke Detector)

A device which senses smoke by projecting a light beam from a transceiver unit across the protected area to a reflector that returns the light signal back to the transceiver unit. Smoke entering the beam path will decrease the light signal causing an alarm.

Beam Range

The distance between the transceiver and reflector.

Detector Coverage

The area in which a smoke detector or heat detector is considered to effectively sense smoke and/or heat. This area is limited by applicable listings and codes.

Listed

The inclusion of a device in a list published by a recognized testing organization, indicating that the device has been successfully tested to meet the accepted standards.

Obscuration (Cumulative Obscuration)

The reduction of the ability of light to travel from one point to another due to the presence of solids, liquids, gases, or aerosols. Cumulative Obscuration is a combination of the density of these light blocking particles per foot and the linear distance which these particles occupy, i.e., smoke density times the linear distance of the smoke field. (Usually expressed in units such as %/foot or %/meter).

Reflector

The device which returns the light signal back to the transceiver unit.

Sensitivity

The ability of a smoke detector to respond to a given level of smoke.

Smoke

The solid and gaseous airborne products of combustion.

Smoke Color

The relative lightness or darkness of smoke, ranging from invisible to white to gray to black.

Smoke Density

The relative quantity of solid and gaseous airborne products of combustion in a given volume.

Spot-Type Detector

A device that senses smoke and/or heat at its location only. Spot-type detectors have a defined area of coverage.

Stratification

The effect which occurs when smoke, which is hotter than the surrounding air, rises until equal to the temperature of the surrounding air, causing the smoke to stop rising.

Transceiver

The device in a reflected beam smoke detector which projects and monitors the light across the protected area.

Transparencies (Filters)

A panel of glass or plastic having a known level of obscuration, which can be used to test the proper sensitivity level of a beam smoke detector.

Trouble Condition

The status of a device or system which impairs its proper operation, i.e., open circuit on an initiation loop. The notification of a trouble condition indicated on a control panel or annunciator is a "TROUBLE" SIGNAL.

Appendix B

NFPA 92B Standard for Smoke Management Systems in Malls, Atria, and Large Spaces 2005 Edition

There is no sure way of identifying what condition will be present at the start of a fire. Any of the following detection schemes can provide for prompt detection regardless of the condition present at the time of fire initiation:

- (a) **An Upward Beam to Detect the Smoke Layer.** The purpose of this approach is to quickly detect the development of a smoke layer at whatever temperature condition exists. One or more beams are aimed at an upward angle to intersect the smoke layer regardless of the level of smoke stratification. For redundancy when using this approach, more than one beam smoke detector is recommended.
- (b) **Horizontal Beams to Detect the Smoke Layer at Various Levels.** The purpose of this approach is to quickly detect the development of a smoke layer at whatever temperature condition exists. One or more beam detectors are located at the ceiling. Additional detectors are located at other levels lower in the volume. The exact positioning of the beams is a function of the specific design but should include beams at the bottom of any identified unconditioned (dead-air) spaces and at or near the design smoke level with several intermediate beam positions at other levels.
- (c) **Beams to Detect the Smoke Plume.** The purpose of this approach is to detect the rising plume rather than the smoke layer. For this approach, an arrangement of beams close enough to each other to assure intersection of the plume is installed at a level below the lowest expected stratification level. The spacing between beams is based on the narrowest potential width of the plume at the level of detection.



advanced ideas. advanced solutions.™

8 0 0 / 7 3 6 - 7 6 7 2
www.systemsensor.com